

Specifications - Installation and Operating Instructions

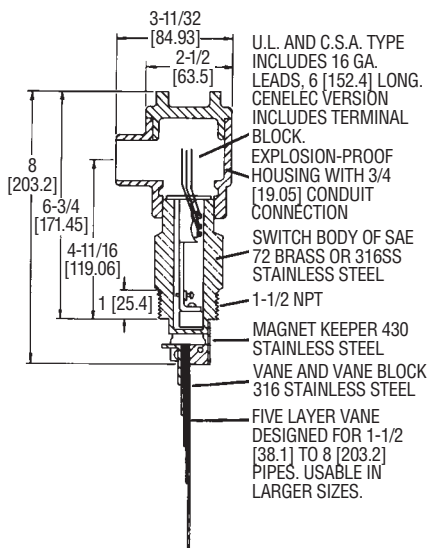

Rugged and reliable the Flotect® V4 flow switch operates automatically to protect equipment and pipeline systems against damage from reduction or loss of flow. The V4 is time tested being installed in thousands of pipelines and processing plants around the world. A unique magnetically actuated switching design gives superior performance. There are no bellows, springs, or seals to fail. Instead, a free-swinging vane attracts a magnet within the solid metal switch body, actuating a snap switch by means of a simple lever arm.

FEATURES

- Leak proof body machined from bar stock
- Choice of custom vane calibrated for your application, Model V4, or field adjustable multilayer vane, Model V4-2-U (see set point chart on page 4)
- Weatherproof, designed to meet NEMA 4
- Explosion-proof (listing included in specifications)
- Installs directly and easily into pipeline with a thredolet, tee, or flange (see application drawings on page 4)
- Can be used in pipes 1-1/2" and up
- Electrical assembly can be easily replaced without removing the unit from installation so that the process does not have to be shut down
- High pressure rating of 1000 psig (69 bar) with the brass body and 2000 psig (138 bar) with the 316 SS body

APPLICATIONS

- Protects pumps, motors and other equipment against low or no flow
- Controls sequential operation of pumps
- Automatically starts auxiliary pumps and engines
- Stops liquid cooled engines, machines and processing when coolant flow is interrupted
- Shuts down burner when air flow through heating coil fails
- Controls dampers according to flow

SPECIFICATIONS

Service: Gases or liquids compatible with wetted materials.

Wetted Materials:

Vane: 316 SS

Body: Brass or 316 SS standard.

Magnet Keeper: 430 SS standard, 316 SS optional.

Options: Other materials also available, consult factory (e.g. PVC, Hastelloy, Nickel, Monel, Titanium).

Temperature Limit: -4 to 275°F (-20 to 135°C) standard, MT high temperature option 400°F (205°C) [MT option not UL, CSA, ATEX, or SAA].

Pressure Limit: Brass body 1000 psig (69 bar), 316 SS body 2000 psig (138 bar), optional 5000 psig (345 bar) available with 316 SS body and SPDT switch only.

Enclosure Rating: Weatherproof and Explosion-proof. Listed with UL and CSA for Class I, Groups C and D; Class II, Groups E, F, and G. ATEX **CE** 0344 **Ex** II 2 G EEx d IIB T6 -20°C ≤ Tamb ≤ 75°C EC-Type Certificate No.: KEMA 03ATEX 2383

SAA: Exd II C T6 (T amb=60°C).

Zone I. Also FM approved.

Switch Type: SPDT snap switch standard, DPDT snap switch optional.

Electrical Rating: UL, FM, ATEX and SAA models 10A @ 125/250 VAC (V~). CSA models: 5A @ 125/250 VAC (V~); 5A res., 3A ind. @ 30 VDC (V=). MV option: 1A @ 125 VAC (V~); 1A res., .5A ind. @ 30 VDC (V=). MT option: 5A @ 125/250 VAC (V~). [MT and MV option not UL, CSA, FM, ATEX or SAA].

Electrical Connections: UL and CSA models: 16 AWG, 6" (152 mm) long. ATEX and SAA unit: Terminal block.

Conduit Connection: 3/4" female NPT.

Process Connection: 1-1/2" male NPT.

Mounting Orientation: Within 5° of vertical for proper operation. Units for horizontal installation (vertical pipe with up flow) available.

Set Point Adjustment: For universal vane: five vane combinations.

Weight: 4 lb 8 oz (1.9 kg).

Notes:

- Check all ratings given in the instructions and on the product to make sure that the product is suitable for your application. Do not exceed electrical ratings, pressure ratings, or temperature ratings of the product.
- Disconnect power supply before beginning installation to prevent possible equipment damage or electrical shock.

MAINTENANCE

Inspect and clean wetted parts at regular intervals. The cover should be in place at all times to protect the internal components from dirt, dust, and weather, and to maintain hazardous location ratings. Disconnect device from the supply circuit before opening to prevent ignition of hazardous atmosphere.

Example	V4	SS	3	1	6	C	F	2	S	1	V4-SS-316-C-F2S1
Construction	V4										Brass Body, SPDT Switch
Construction Options		SS 2 D U									316 SS Body Type 2 Body Style DPDT Switch Universal Vane (Omit for a custom vane)
Magnet Keeper Material Options			1 2 3								430 SS (Standard) Nickel 200 316 SS
Vane Material Options				1 2 3 4 5							316 SS (Standard) Carpenter 20 Hastelloy B Hastelloy C Monel
Body Material Options					1 2 3 4 5 6 7						Brass (Standard) Carpenter 20 CPVC* Hastelloy B Hastelloy C 316 SS (Must also use SS construction selection) Monel
Other Options						AT SAA EPOXY FSV FTR HP HV MT MV NACE NB NH SW TBC TRD TRI V					ATEX SAA Construction* Epoxy Coated Housing Full Swing Vane Flow Test Report High Pressure*, 5000 psi (345 bar) (Only with SS body) Hinged Vane High Temperature* (See specifications for rating) Gold Contact Snap Switch* (See specifications for rating) NACE Heat Treated Body* Neoprene Boot* No Electrical Housing* Socket Weld Connection* Terminal Block Wire Connections* Time Delay Relay* (On flow decrease) Time Delay Relay* (On flow increase) Vertical Up Flow Applications
Flange*							F				Flange Process Connection
Flange Size								2 2.5 3 4			2" 2-1/2" 3" 4"
Flange Material									C S M B H		Carbon Steel 316 SS Monel Hastelloy B Hastelloy C
Flange Rating										1 3 6 9	150# 300# 600# 900#
Bushing*							B				Bushing Process Connection
Bushing Size								1 2 4			2" 2-1/2" 4"
Bushing Type									H F		Hex Flush
Bushing Material										B C S 4	Brass Carbon Steel 316 SS 304 SS
Tee*							T				Tee Process Connection
Tee Size								1			1-1/2"
Tee with Bushing*							TB				Tee with Bushing Process Connection (Both same material)
Tee Size								2 3			2" 3"
Tee Material and Type										B0 B1 B2 C CP S P	Brass 125 # Brass 150 # Brass 250 # Carbon Steel 2000 # (Only with 2" and 3") CPVC SCH 80 316 SS 150 # PVC SCH 80

* Options that do not have ATEX

Attention: Units without the "AT" suffix are not Directive 94/9/EC (ATEX) compliant. These units are not intended for use in potentially hazardous atmospheres in the EU. These units may be CE marked for other Directives of the EU.

INSTALLATION

- Remove packing material from switch body-cap and remove tape from magnet keeper. Adjust vane length if necessary on multi-layer vanes only (see flow rate charts on next page). Install switch in thredolet previously welded to line. In some cases, it may be necessary to install the switch in a flange or tee (see installation drawings on next page). Note: extreme care must be exercised in welding the fitting to the line so that it is plumb and level.

ADJUSTMENT OF MULTI-LAYER VANE

Remove only those layers which are too long. Leave the smaller layers to reinforce the vane. The longest vane fits 6" (150 mm) or larger pipe, the second longest vane fits 4" (100mm) pipe, etc. Actuation-Deactuation rates are shown in the charts on the next page. To remove vane layers, proceed as follows:

- Remove the two screws and lockwashers holding the layers together. Do not lose these special corrosion resistant type 316 stainless steel screws and lockwashers.
- Remove the unwanted layers.
- Resecure the vane with the original two screws and lockwashers.
- With a hammer, lightly peen the ends of the screws so that they can't back out.
- If you lose the screws or lockwashers, don't replace with other parts which may corrode and break. That will void the warrantee and might cause severe damage to equipment located downstream of the switch.

Note: Custom vane units have been calibrated at factory to meet requirements. Do not change.

- The arrow on the side of the switch must point in the direction of flow.
- Wiring: UL and CSA units only: thread connecting wires through conduit and connect. Wire in accordance with local electrical codes.
Black - Common
Blue - N.O.
Red - N.C.

Note: Double pole, double throw switches have dual black, blue and red leads. These are connected in the same manner as single pole, double throw switches, as described above.

EC-Type Certificate Installation Instructions:

Cable Connection

The cable entry device shall be an EEx d certified cable gland suitable for conditions of use and correctly installed. The certified cable gland and cable shall be rated for a minimum temperature of 80°C.

Conduit Connection

An EEx d certified seal device such as a conduit seal with setting compound suitable for conditions of use and correctly installed shall be provided immediately to the entrance of the electrical housing. The certified conduit seal with setting compound and cable shall be rated for a minimum temperature of 80°C.

Note: The switch is deactivated and contacts are in normal condition when there is no flow in the line.

- Make sure conduit or cable are properly sealed. Electrical components must be kept free of moisture, including condensation, at all times. **CAUTION:** To prevent ignition of hazardous atmosphere, disconnect the device from the supply circuit before opening. Keep assembly tightly closed when in operation.

Note: ATEX units only: The temperature class is determined by the maximum ambient or medium/process temperature. The approved ratings are: T6 $-20^{\circ}\text{C} \leq T_{\text{amb}} \leq 75^{\circ}\text{C}$. Product may be used in a maximum ambient or medium/process temperature of 75°C.

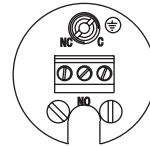
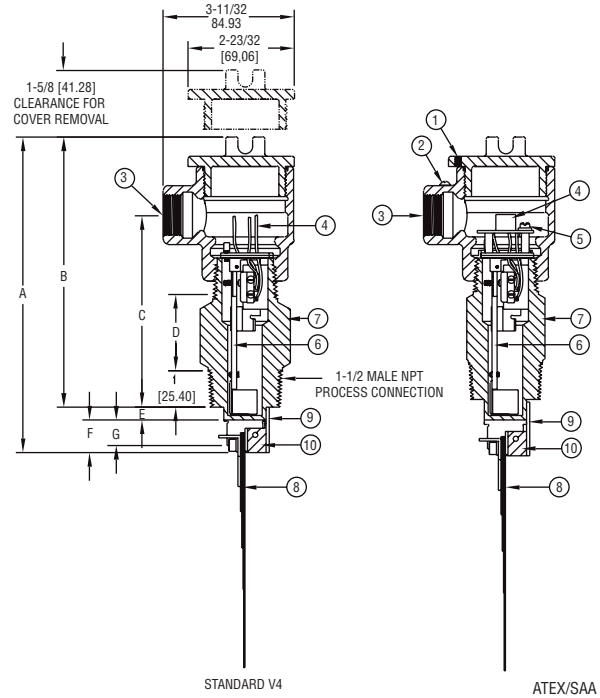

TERMINAL CONNECTIONS
SPDT

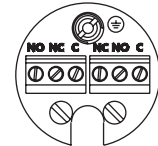

TERMINAL CONNECTIONS
DPDT

Dim	V4 in(mm)	V4-2 in(mm)
A	8-3/16 (207.96)	8 (203.20)
B	6 (152.40)	6-3/4 (171.45)
C	4-11/16 (119.06)	3-15/16 (100.01)
D	1 (25.40)	1-3/4 (44.45)
E	1-5/16 (33.34)	9/16 (14.30)
F	7/8 (22.23)	11/16 (17.63)
G	11/16 (17.46)	1/2 (12.70)

Ref #	Standard V4	ATEX/SAA
1	N/A	Cover lock.
2	N/A	External ground.
3	Explosion-proof housing with 3/4" female NPT conduit connection.	Explosion-proof housing with 3/4" female NPT conduit connection.
4	16 AWG, 6" (152 mm) long.	Terminal Block
5	Internal	Internal ground.
6	Magnet arm and switch assembly.	Magnet arm and switch assembly.
7	Switch body of SAE 72 Brass or 316 Stainless Steel.	Switch body of SAE 72 Brass or 316 Stainless Steel.
8	Five layer vane, 316 Stainless Steel, Designed for 1/2" to 8" pipes. Usable in larger pipe sizes.	Five layer vane, 316 Stainless Steel, Designed for 1/2" to 8" pipes. Usable in larger pipe sizes.
9	Magnet keeper of 430 Stainless Steel.	Magnet keeper of 430 Stainless Steel.
10	Vane block of 316 Stainless Steel.	Vane block of 316 Stainless Steel.

V4 Universal Vane Flow Charts

Values shown in both charts are nominal. If normal flows exceed actuation rates by less than 10%, custom vanes are recommended. Figures are based on standard vertical installation in a 1-1/2" thredolet in a horizontal run of pipe.

APPROXIMATE ACTUATION/DEACTUATION FLOW RATES FOR COLD WATER. UPPER FIGURES IN GPM. LOWER FIGURES IN LPM												
VANE LAYERS	1.5"PIPE	2"PIPE	3"PIPE	4"PIPE	6"PIPE	8"PIPE	10"PIPE	12"PIPE	14"PIPE	16"PIPE	18"PIPE	20"PIPE
1	7-3 26.67-11.67	15-8 56.7-30	45-22 167-83.3	95-40 367-150	210-120 800-450	375-175 1417-667	600-300 2267-1133	900-450 3400-1700	1200-600 4550-2267	1400-800 5300-3033	2000-1000 7567-3783	2400-1200 9083-4550
1&2		7-4 26.7-15	23-14 86.7-53.3	50-35 190-132	130-90 500-333	230-150 867-567	450-250 1700-950	650-350 2467-1317	900-500 3400-1900	1200-650 4550-2467	1450-800 5483-3033	1800-1000 6817-3783
1,2,&3			11-7 41.7-26.7	27-19 102-71.7	80-60 300-233	160-115 600-433	300-180 1133-683	450-275 1700-1033	600-350 2267-1317	750-450 2750-2083	1000-600 3783-2267	1200-700 4550-2650
1,2,3,&4				17-12 65-45	60-45 233-167	120-90 450-333	230-150 867-567	310-200 1167-750	430-280 1633-1067	550-360 2083-1367	700-450 2650-1700	850-550 3217-2083
1,2,3,4,&5					40-30 152-113	80-65 300-250	135-100 517-383	200-140 750-533	290-200 1100-750	360-250 1367-950	460-325 1733-1233	575-400 2183-1517

Actuation rates are based on cold water at a specific gravity of 1.0. For fluids of different specific gravity, actuation rates may be approximated by dividing the rate shown by the square root of the specific gravity.

APPROXIMATE ACTUATION/DEACTUATION FLOW RATES FOR AIR. UPPER FIGURES IN SCFM. LOWER FIGURES IN LPS												
VANE LAYERS	1.5"PIPE	2"PIPE	3"PIPE	4"PIPE	6"PIPE	8"PIPE	10"PIPE	12"PIPE	14"PIPE	16"PIPE	18"PIPE	20"PIPE
1	32-17 15-8	65-32 30-20	210-105 100-50	400-200 190-90	950-475 450-220	1550-850 730-400	2400-1300 1100-600	3450-1900 1600-900	4700-2600 2200-1200	6400-3500 3000-1700	8000-4400 3800-2100	10000-5500 4700-2600
1&2		23-13 10-6	120-70 60-30	195-140 90-70	550-375 260-180	1100-700 520-330	1850-1200 870-570	2700-1750 1300-800	3400-2200 1600-1000	4800-3100 2300-1500	6000-3900 2800-1800	7400-4800 3500-2300
1,2,&3			60-48 30-20	135-100 60-50	375-265 180-130	725-500 340-240	1200-850 570-400	1850-1300 870-610	2600-1800 1200-800	3350-2350 1600-1100	4300-3000 2000-1400	5300-3700 2500-1700
1,2,3,&4				65-50 30-20	260-200 120-90	500-400 240-190	875-700 410-330	1250-1000 590-470	1900-1500 900-710	2500-2000 1200-900	3100-2500 1500-1200	3900-3100 1800-1500
1,2,3,4,&5					130-100 60-50	310-250 150-120	650-525 310-250	1000-800 470-380	1600-1250 760-590	2200-1750 1040-830	2800-2250 1300-1100	3550-2850 1700-1300

Actuation rates are based on air at standard conditions. For gases at other pressures, temperatures, or specific gravities, consult factory for equivalent flow approximations.

APPLICATION DRAWINGS FOR FLOTECT® AUTOMATIC FLOW SWITCHES

