

**Specifications - Installation and Operating Instructions**

**Rugged and reliable** the Flotect® L4 Level switch operates automatically to indicate tank level. Perfect for starting or stopping pumps, opening or closing valves, or actuate level alarm signals. A unique magnetically actuated switching design gives superior performance. There are no bellows, springs, or seals to fail. Instead, the free-swinging float attracts a magnet within the solid metal switch body, actuating a snap switch by means of a simple lever arm. Float arm hinge design limits the arm angle to prevent vertical hangup.

**FEATURES**

- Leak proof body machined from bar stock
- Choice of floats dependent on maximum pressure and specific gravity
- Weatherproof, designed to meet NEMA 4
- Explosion-proof (listings included in specifications)
- Installs directly and easily into tank with a thredolet or flange (see application drawings on page 4)
- Electrical assembly can be easily replaced without removing the unit from the installation so that the process does not have to be shut down.
- Horizontal installation or optional top mount vertical installation

**APPLICATIONS**

- Direct pump control for maintaining level
- Automatic tank dump operations
- Control levels or provide alarms in sumps, scrubber systems, hydro-pneumatic tanks, low pressure boilers, and various waste water/sewage treatment processes

**SPECIFICATIONS**

**Service:** Liquids compatible with wetted materials.

**Wetted Materials:**

**Float and Rod:** 316 SS

**Body:** Brass or 316 SS standard.

**Magnet Keeper:** 430 SS standard, 316 SS or Nickel optional.

**Temperature Limits:** 4 to 275°F (-20 to 135°C) standard, MT high temperature option 400°F (205°C) [MT option not UL, CSA, ATEX, or SAA].

**Pressure Limit:** Brass body 1000 psig (69 bar), 316 SS body 2000 psig (138 bar). Standard float rated 100 psig (6.9 bar). For other floats see model chart on next page.

**Enclosure Rating:** Weatherproof and Explosion-proof. Listed with UL and CSA for Class I, Groups C and D; Class II, Groups E, F, and G. ATEX **CE** 0344 **Ex** II 2 G EEx d IIB T6 -20°C ≤ Tamb ≤ 75°C EC-Type Certificate No.: KEMA 03 ATEX 2383

SAA: Exd II C T6 (T amb = 60°C).

IP66 C1 I, Zone I. Also FM approved.

**Switch Type:** SPDT snap switch standard, DPDT snap switch optional.

**Electrical Rating:** UL, FM, ATEX and SAA models: 10A @ 125/250 VAC (V~). CSA models: 5A @ 125/250 VAC (V~); 5A res., 3A ind. @ 30 VDC (V=). MV option: 1A @ 125 VAC (V~); 1A res., .5A ind. @ 30 VDC (V=). MT option: 5A @ 125/250 VAC (V~). [MT and MV option not UL, CSA, FM, ATEX or SAA].

**Electrical Connections:** UL and CSA models: 16 AWG, 6" (152 mm) long. ATEX and SAA unit: terminal block.

**Process Connection:** 1-1/2" male NPT standard, 2-1/2" male NPT standard optional floats.

**Mounting Orientation:** Horizontal installation standard, optional vertical top mount.

**Weight:** 4 lbs. 9 oz. (2.07 kg).

**Dead Band:** 3/4" (19 mm) for standard float.

**Specific Gravity:** 0.7 minimum with standard float. For other floats see model chart.

<b>Example</b>	L4	SS	D		C	F	2	C	1	L4-SS-D-C-F2C1
<b>Construction</b>	L4 L4-TOP									Side Mount, Brass Body, SPDT Switch Top Mount, Brass Body, SPDT Switch (Specify rod length)
<b>Wetted Material Options</b>		SS 316 NI								316 SS Body with 430 SS Magnet Keeper 316 SS Body and Magnet Keeper (Order with SS option) Nickel 20 Magnet Keeper
<b>Switch Options</b>			D							DPDT Switch
<b>Float Options</b>				50 150 300						2-1/2" Spherical, 304 SS rated 50 psi (3.5 bar), > 0.5 s.g. 2-1/2" Spherical, 316 SS rated 150 psi (10.3 bar), > 0.7 s.g. 2-1/2" Spherical, 304 SS rated 300 psi (20.7 bar), > 0.7 s.g.
<b>Other Options</b>					AT SAA EPOXY MT MV NB NH TBC TRD TRI					ATEX SAA Construction Epoxy Coated Housing High Temperature* (See specifications for rating) Gold Contact Snap Switch* (See specifications for rating) Neoprene Boot* No Electrical Housing* Terminal Block Wire Connections* Time Delay Relay* (On flow decrease) Time Delay Relay* (On flow increase)
<b>Flange*</b>						F				Flange Process Connection
<b>Flange Size</b>							2 3 4			2" 3" 4"
<b>Flange Material</b>								C S		Carbon Steel 316 SS
<b>Flange Rating</b>									1 3 6 9	150 # 300 # 600 # 900 #
<b>Bushing*</b>						B				Bushing Process Connection
<b>Bushing Size</b>							1 2 4			2" 2-1/2" 4"
<b>Bushing Type</b>								H F		Hex Flush
<b>Bushing Material</b>									B C S 4	Brass Carbon Steel 316 SS 304 SS

\* Options that do not have ATEX

**Attention:** Units without the "AT" suffix are not Directive 94/9/EC (ATEX) compliant. These units are not intended for use in potentially hazardous atmospheres in the EU. These units may be CE marked for other Directives of the EU.

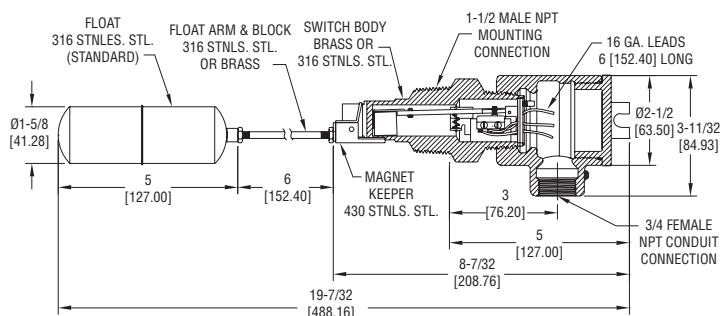

UL/CSA unit

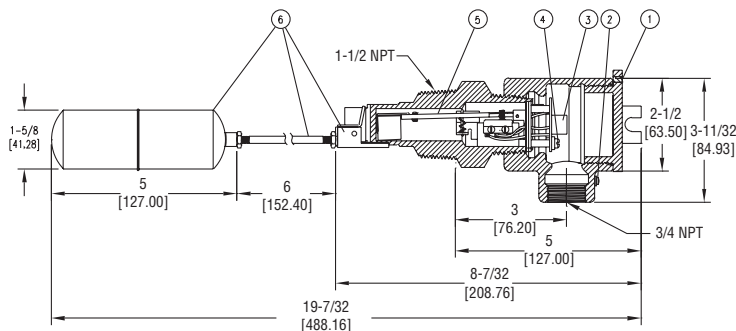

ATEX/SAA unit

## PARTS LIST

1. Cover lock. (ATEX/SAA unit only).
  2. External ground. (ATEX unit only).
  3. Enclosure housing and cover.
  4. Terminal block. (ATEX and SAA unit only, UL/CSA unit has 6" leads).
  5. Internal ground.
  - \* 6. Magnet arm and switch assembly.
  7. Switch body.
  - \* 8. Float, arm and block assembly.
- \* Approved replacement parts

## INSTALLATION

### NOTES:

- Check all ratings given in the instructions and on the product to make sure that the product is suitable for your application. Do not exceed electrical ratings, pressure ratings, or temperature ratings of the product.

- Disconnect power supply before beginning installation to prevent possible equipment damage or electrical shock.

1. Remove packing material from switch body-cap and remove tape from magnet keeper. Install standard switch in thredolet previously welded to tank. Install optional switch mountings per application drawings. Make sure locknuts on float are tight.

2. When mounting switch in the side of a tank, the arrow on the side of the switch must point up.

3. Wiring: **UL and CSA units only:** Thread connecting wires through conduit and connect. Wire in accordance with local electrical codes.

Black - Common  
Blue - N.O.  
Red - N.C.

**NOTE:** Double pole, double throw switches have dual black, blue and red leads. These are connected in the same manner as single pole, double throw switches, as described above.

EC-Type Certificate Installation Instructions:

Cable Connection

The cable entry device shall be an EEx d certified cable gland suitable for conditions of use and correctly installed. The certified cable gland and cable shall be rated for a minimum temperature of 80°C.

Conduit Connection

An EEx d certified seal device such as a conduit seal with setting compound suitable for conditions of use and correctly installed shall be provided immediately to the entrance of the electrical housing. The certified conduit seal with setting compound and cable shall be rated for a minimum temperature of 80°C.

**NOTE:** The switch is deactivated and contacts are in normal condition when the liquid is below the float.

4. Make sure conduit or cable are properly sealed. Electrical components must be kept free of moisture, including condensation, at all times.

**CAUTION:** To prevent ignition of hazardous atmosphere, disconnect the device from the supply circuit before opening. Keep assembly tightly closed when in operation.

**NOTE: ATEX units only:** The temperature class is determined by the maximum ambient or medium/process temperature. The approved ratings are: T6  $-20^{\circ}\text{C} \leq T_{\text{amb}} \leq 75^{\circ}\text{C}$ . Product may be used in a maximum ambient or medium/process temperature of 75°C.

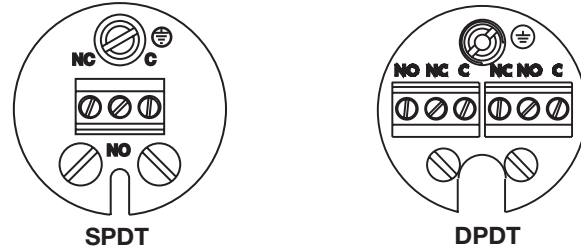

**TERMINAL CONNECTIONS**

## MAINTENANCE

Inspect and clean wetted parts at regular intervals. The cover should be in place at all times to protect the internal components from dirt, dust, and weather, and to maintain hazardous location ratings. Disconnect device from the supply circuit before opening to prevent ignition of hazardous atmosphere.

# APPLICATION DRAWINGS FOR FLOTECT® AUTOMATIC FLOAT SWITCHES

